

PRODUCT SHEET

VIEW THIS
PRODUCT
ONLINE



LENGTH	2400MM
WIDTH	1850MM
HEIGHT	2480MM

All dimensions may vary ± 3% due to rotational moulding process.



**PRODUCT CODE:
OFSDI5000FBB**

5,000L DIESEL ON FARM TANK

FEATURES

- Specific Gravity of 1.6
- Fully self supporting roof (no internal poles or frames)
- Tanks can be daisy chained for extra storage
- Manufactured from proven Australian standard materials (tested in the field for over 25years)
- Manufactured in computerised ovens (not open flame)
- Thicker walls at base (supports pressure)
- Poly fused and welded fittings (stops fitting split)

FREE INCLUSIONS

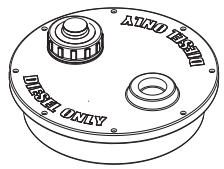
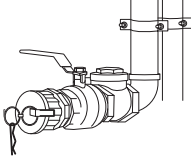
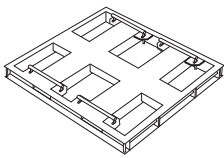
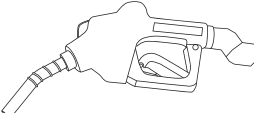
Vented Lid 	Truck Fill Point 
Heavy Duty Alloy Frame 	Bowser with Diesel Auto Shut-Off Nozzle 

*Inclusions may change without notice, check with sales prior to ordering

COLOURS AVAILABLE



Grey

NB: Colours may vary due to screen and printer calibrations.

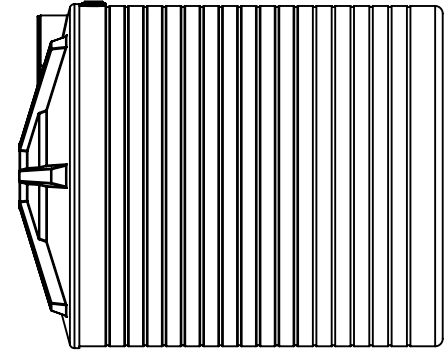
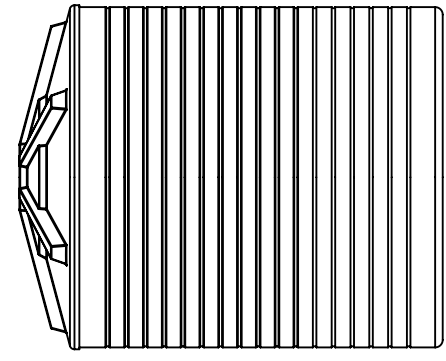
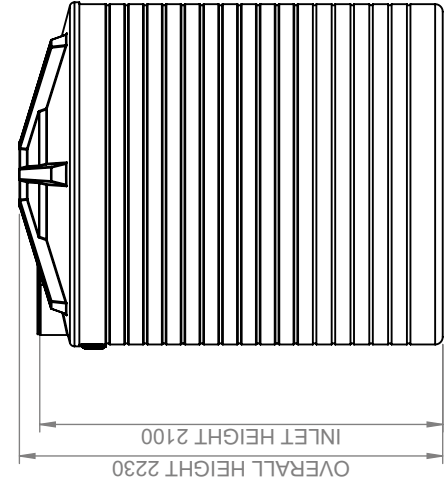
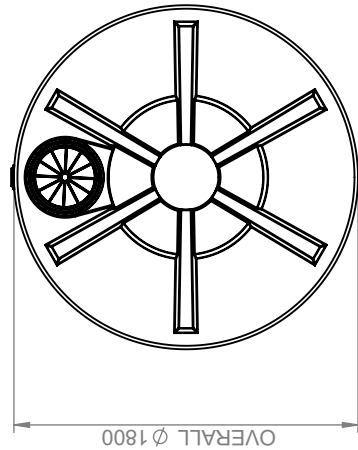

Details

Manufacturer's Name	Nu-Tank Pty Ltd
Tank Capacity	5000 Litre
Specific Gravity	1.6
Maximum Design Service Temperature	23°C
Standard	AS/NZS 4766

All dimensions may vary ± 3% due to rotational moulding process.

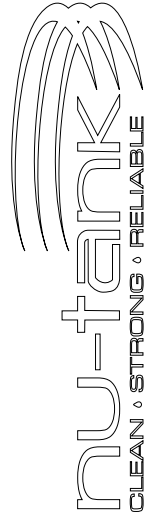

PRODUCT CODE:

0FSDI5000FBB

DESCRIPTION

5 000 LITRE ON FARM DIESEL TANK