

## PRODUCT SHEET

HEIGHT	250MM
LENGTH	420MM
WIDTH	400MM



**PRODUCT CODE:  
PFDF35**

**D FEEDER**

### FEATURES

- Made to last with proven food grade materials, BPA free, heavy metal free
- Heavy duty construction (won't crack or perish)
- Manufactured in computerised ovens
- Convenient Galvanised brackets, allows for feeder to be hung at different heights to suit needs of a variety of stock

### COLOURS AVAILABLE

CB Surf Mist	Birch Grey (CB Dune)	CB Shale Grey	Armour Grey (CB Windspray)	CB Wallaby	CB Basalt	Slate Grey (CB Woodland Grey)
CB Monument	Black (CB Night Sky)	Mountain Blue (CB Deep Ocean)	Metal Grey (CB Ironstone)	CB Cove	Evening Haze	Merino Beige (CB Paperbark)
Gully	CB Jasper	Smooth Cream (CB Classic Cream)	Desert Haze (CB Sandbank)	Wheat	Earthtone (CB Bushland)	CB Mangrove
Mist Green (CB Pale Eucalypt)	Rivergum (CB Wilderness)	Heritage Green (CB Cottage Green)	Heritage Red (CB Manor Red)	<small>NB: COLORBOND® and colour names are registered trademarks of BlueScope Steel Limited®. Colour names, shown in brackets, are trademarks of BlueScope Steel Limited). Colours may vary due to screen and printer calibrations.</small>		

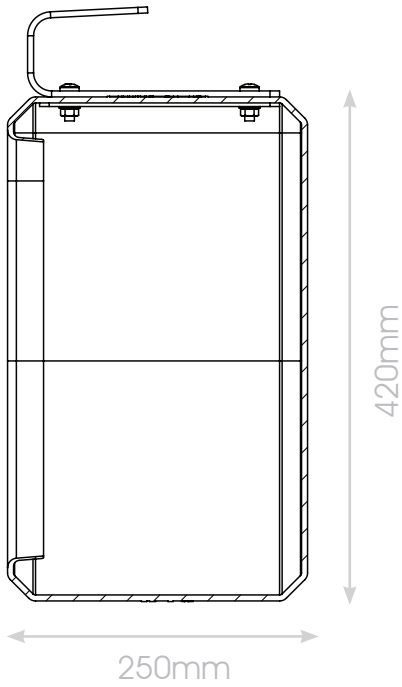
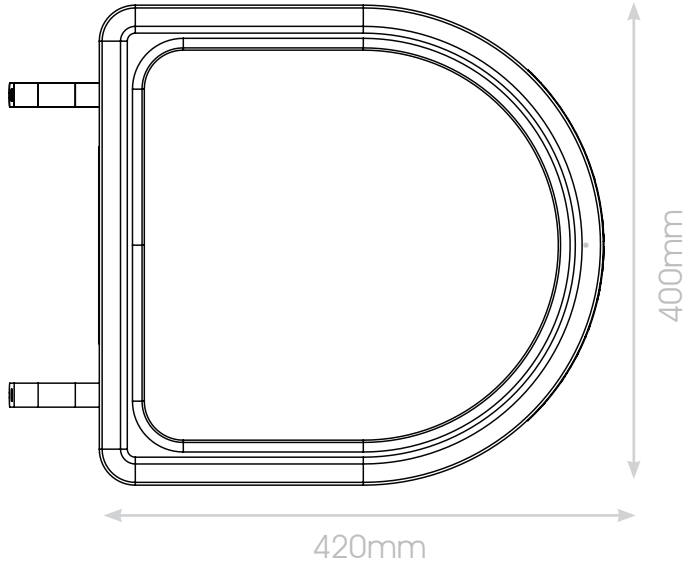
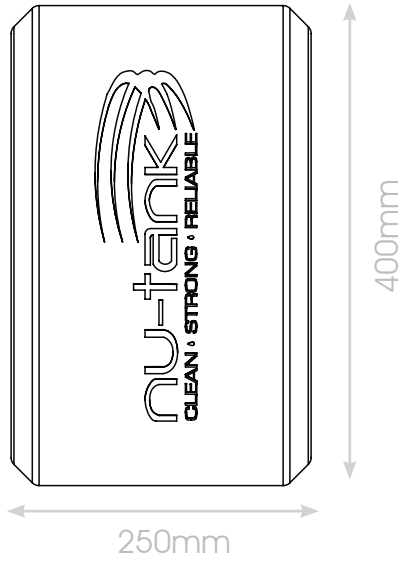

PRODUCT CODE:

PFDF35

DESCRIPTION

D FEEDER

### Details

Manufacturer's Name	Nu-Tank Pty Ltd
Tank Capacity	35L
Standard	AS/NZS4766