

PRODUCT SHEET



HEIGHT	840MM
LENGTH	500MM
WIDTH	600MM

**PRODUCT CODE:
PFHF**

HAY FEEDER

FEATURES

- Generous bay compartment - fits one biscuit of hay
- Lid prevents horse pulling biscuit out of hay rack
- Lid can be purchased separately to fit onto existing feeders
- Feed bin prevents valuable feed from falling onto ground
- Zinc plated hay compartment frame and galvanised brackets

COLOURS AVAILABLE

CB Surf Mist	Birch Grey (CB Dune)	CB Shale Grey	Armour Grey (CB Windspray)	CB Wallaby	CB Basalt	Slate Grey (CB Woodland Grey)
CB Monument	Black (CB Night Sky)	Mountain Blue (CB Deep Ocean)	Metal Grey (CB Ironstone)	CB Cove	Evening Haze	Merino Beige (CB Paperbark)
Gully	CB Jasper	Smooth Cream (CB Classic Cream)	Desert Haze (CB Sandbank)	Wheat	Earthtone (CB Bushland)	CB Mangrove
Mist Green (CB Pale Eucalypt)	Rivergum (CB Wilderness)	Heritage Green (CB Cottage Green)	Heritage Red (CB Manor Red)	<small>NB: COLORBOND® and colour names are registered trademarks of BlueScope Steel Limited®. Colour names, shown in brackets, are trademarks of BlueScope Steel Limited). Colours may vary due to screen and printer calibrations.</small>		

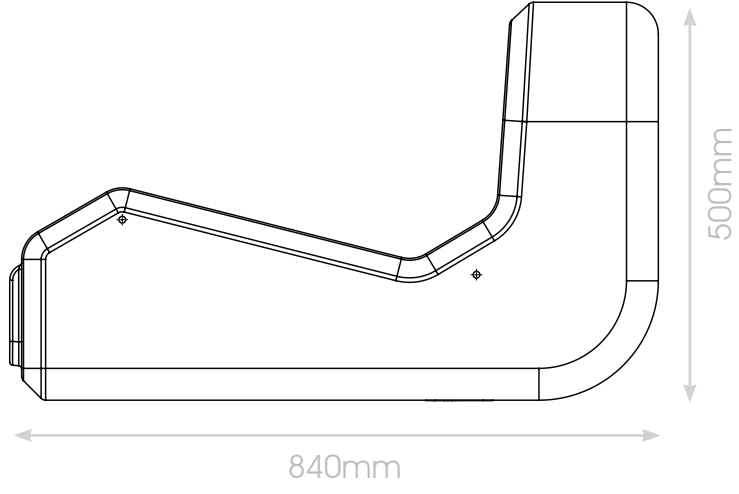
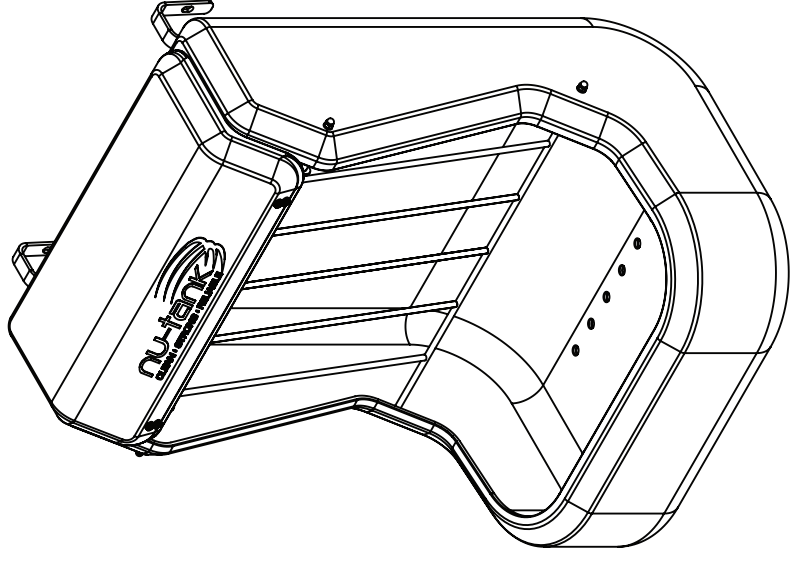
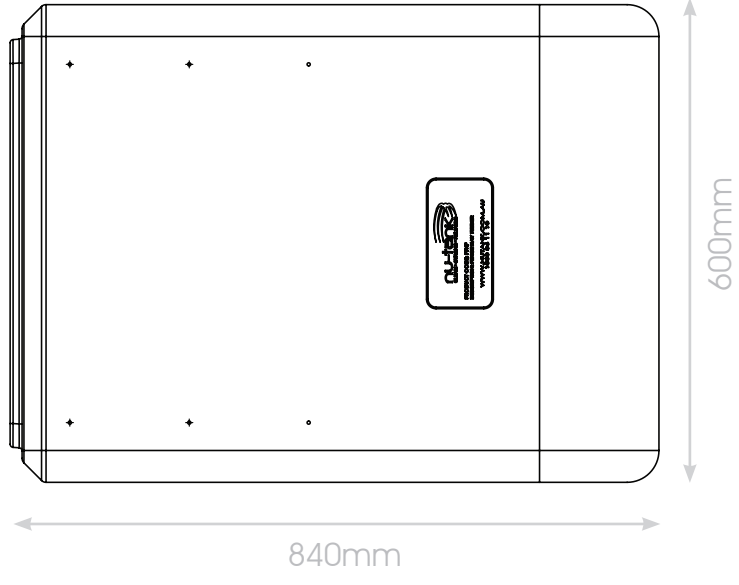

PRODUCT CODE:	PFHF
DESCRIPTION	HAY FEEDER

Details

Manufacturer's Name	Nu-Tank Pty, Ltd
Standard	AS/NZS4766