

PRODUCT SHEET

LENGTH	880 MM
WIDTH	710 MM
TROUGH HEIGHT	340 MM
ROLLER HEIGHT	435 MM



**PRODUCT CODE:
PFRD150**

150L MOLASSES ROLLER DRUM

FEATURES

- Heavy duty construction (all poly - no rust)
- Prevents weather damage of product
- Design that controls livestock intake
- Edge fill (or drum can be removed)
- Manufactured from proven Australian standard materials (tested in the field for over 25 years)
- Manufactured in computerised ovens (not open)
- Removable drum

COLOURS AVAILABLE



Slate Grey

NB: Colours may vary due to screen and printer calibrations.

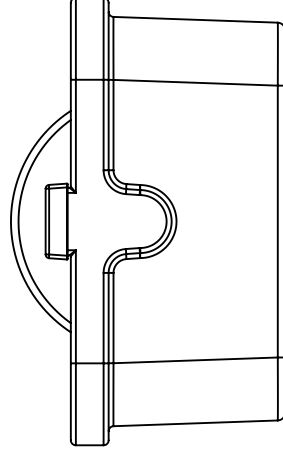
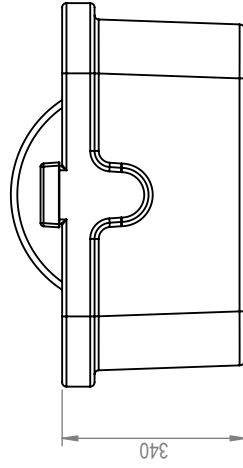
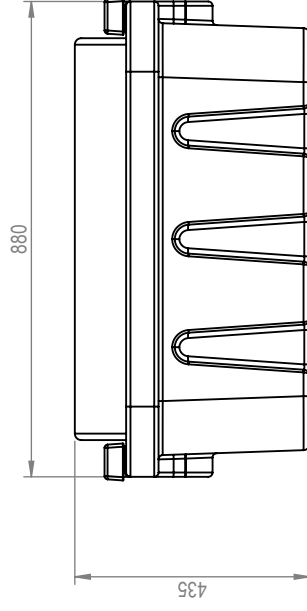
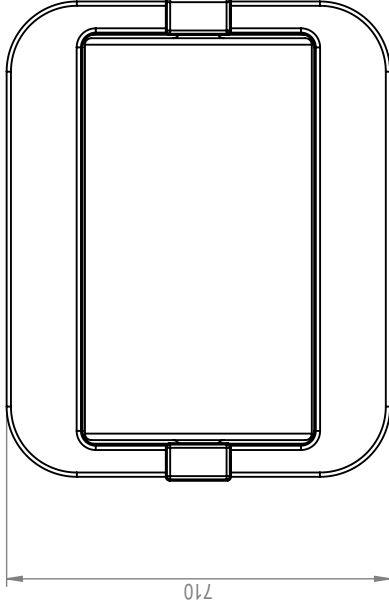

Details

Manufacturer's Name	NU-Tank Pty Ltd
Tank Capacity	150 Litres
Maximum Specific Gravity	1.0
Maximum Design Service Temperature	23°C
Standard	AS/NZS 4766



PRODUCT CODE: PFRDMO150

DESCRIPTION: 150L MOLASSES ROLLER DRUM