

PRODUCT SHEET

DIAMETER	650 MM
HEIGHT	300 MM

**PRODUCT CODE:
 PORNMO50FF**



50L ROUND TROUGH

FEATURES

- Unique anti-crack lip design
- Manufactured from proven UV stabilised Australian standard materials (tested in the field for over 25 years)
- Designed for easy transportation and use
- Heavy duty construction (built to last)
- Moulded indents for easy stacking (prevents suction)

OPTIONAL EXTRAS

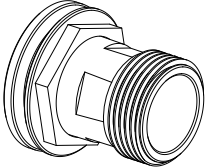
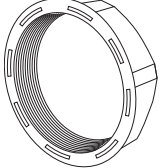
2" Fitting	2" Cap
	

*Please contact sales for a free quote

COLOURS AVAILABLE



Yellow

NB: Colours may vary due to screen and printer calibrations.

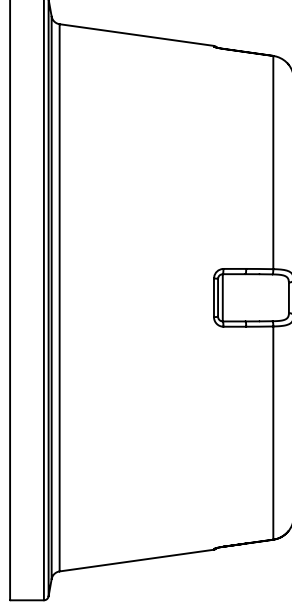
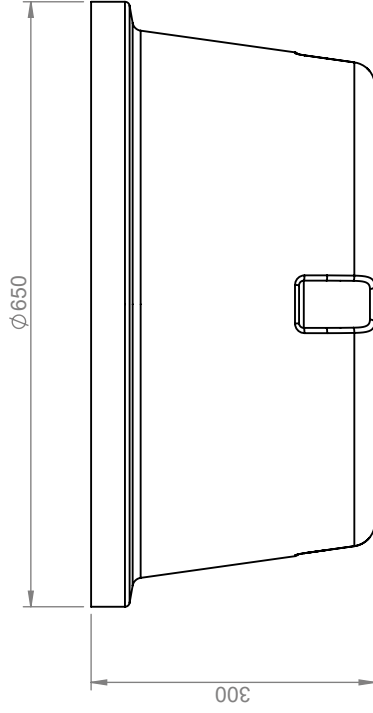
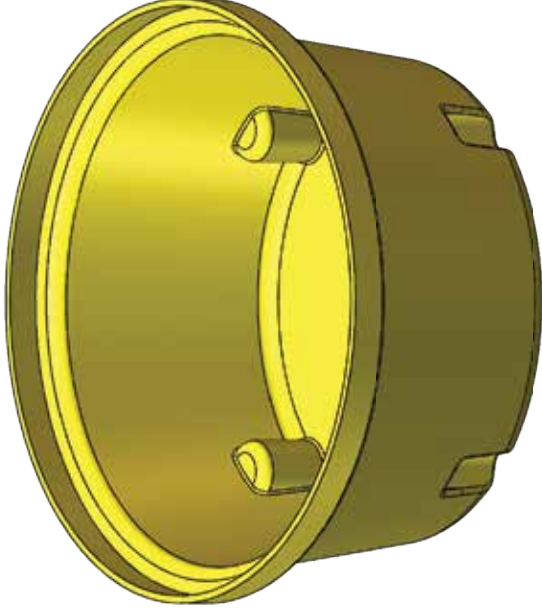
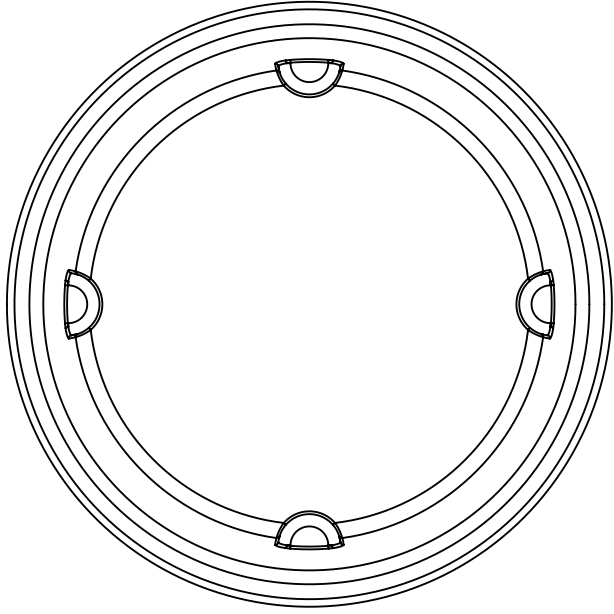

Details

Manufacturer's Name	Nu-Tank Pty Ltd
Tank Capacity	50 Litres
Maximum Specific Gravity	2.0
Maximum Design Service Temperature	23°c
Standard	AS/NZS 4766



PRODUCT CODE:

PORNMO50FF

DESCRIPTION:

50 LITRE ROUND TROUGH