

PRODUCT SHEET



DIAMETER	3700 MM
MAN HOLE HEIGHT	2290 MM
OVERALL HEIGHT	2630 MM

**PRODUCT CODE:
 PTRNFE5500**

5,500GAL / 25,000L LIQUID FERTILISER TANK

FEATURES

- Specific Gravity of 1.6 (2.0 optional)
- Fully self supporting roof (no internal poles or frames)
- Manufactured from proven Australian standard materials (tested in the field for over 25 years)
- Manufactured in computerised ovens (not open flame)
- Ribbed side walls (extra strength)
- Thicker walls at base (supports pressure)
- Poly fused & welded fittings (stops fitting split)

FREE INCLUSIONS¹

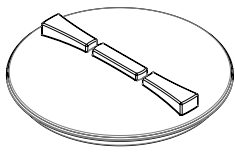
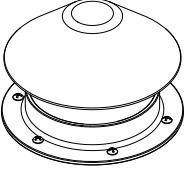
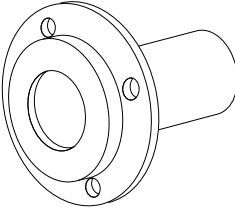
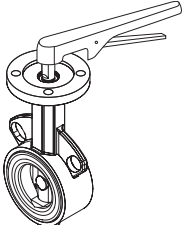
<p>455mm Screw Cap Manhole</p> 	<p>Centre Vent</p> 
<p>Stub Flange</p> 	<p>Butterfly Valve</p> 

¹ Standard sizing of Butterfly Valve and Stub Flange 3", 4" and 6", other sizes available on request

*Inclusions may change without notice, check with sales prior to ordering

COLOURS AVAILABLE



Natural

NB: Colours may vary due to screen and printer calibrations.

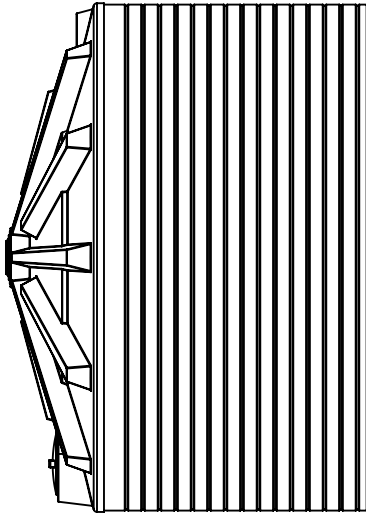
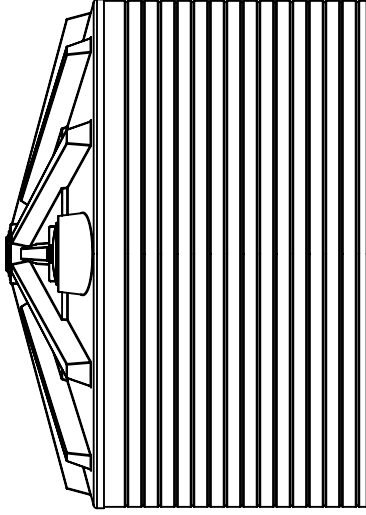
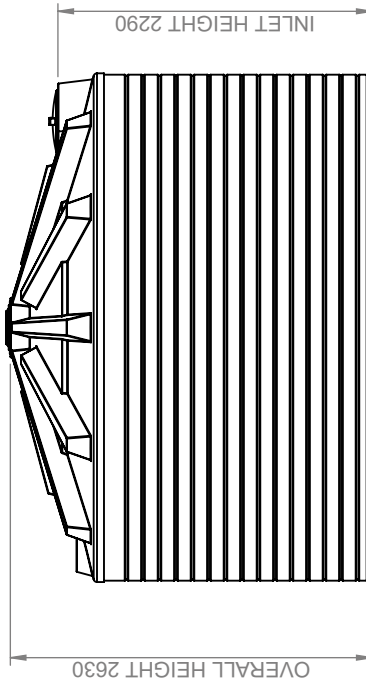
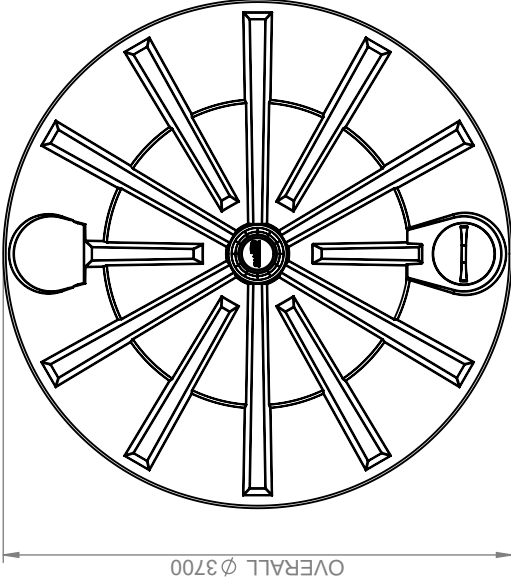

Details

Manufacturer's Name	Nu-Tank Pty Ltd
Tank Capacity	5500 Gallon
Maximum Specific Gravity	2.0
Maximum Design Service Temperature	23°C
Standard	AS/NZS 4766



PRODUCT CODE:

PTRNFE5500

DESCRIPTION:

5,500 GALLON / 25,000 LITRE LIQUID FERTILISER TANK