

PRODUCT SHEET



DIAMETER	3750 MM
MAN HOLE HEIGHT	2610 MM
OVERALL HEIGHT	3040 MM

**PRODUCT CODE:
PTRNFE6200**

6,200GAL / 28,000L LIQUID FERTILISER TANK

FEATURES

- Specific Gravity of 1.6 (2.0 optional)
- Fully self supporting roof (no internal poles or frames)
- Manufactured from proven Australian standard materials (tested in the field for over 25 years)
- Manufactured in computerised ovens (not open flame)
- Ribbed side walls (extra strength)
- Thicker walls at base (supports pressure)
- Poly fused & welded fittings (stops fitting split)

FREE INCLUSIONS¹

455mm Screw Cap Manhole	Centre Vent
Stub Flange	Butterfly Valve

¹ Standard sizing of Butterfly Valve and Stub Flange 3", 4" and 6", other sizes available on request

*Inclusions may change without notice, check with sales prior to ordering

COLOURS AVAILABLE



Natural

NB: Colours may vary due to screen and printer calibrations.

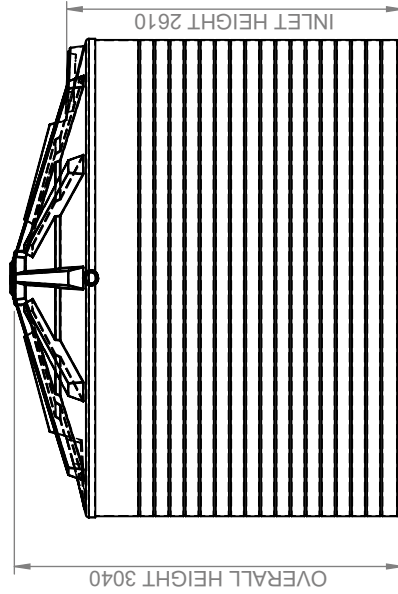
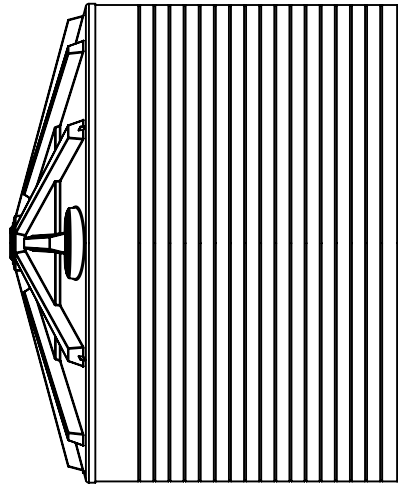
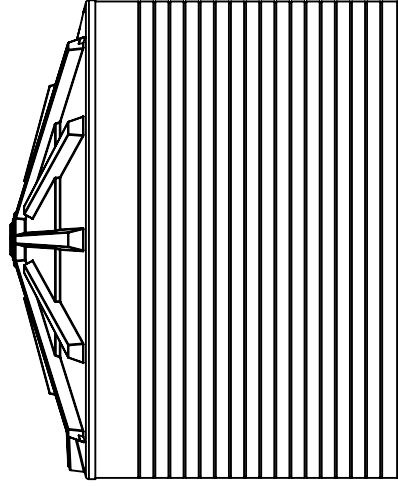
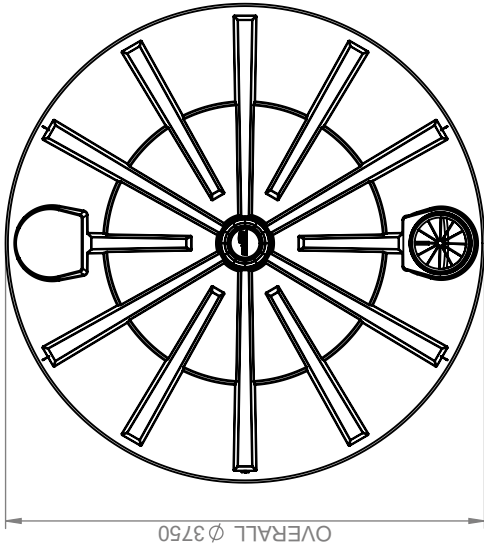
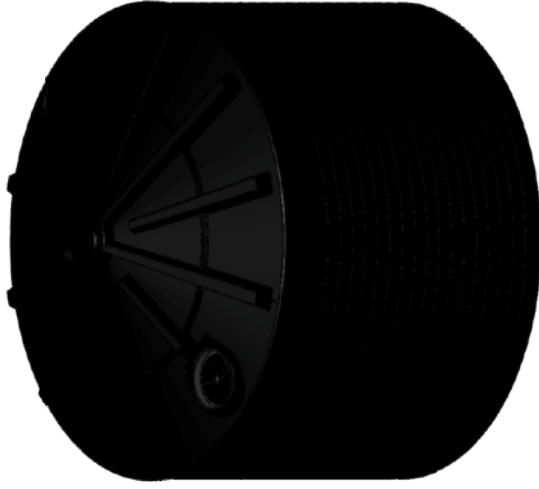

Details

Manufacturer's Name	Nu-Tank Pty Ltd
Tank Capacity	6200 Gallon
Maximum Specific Gravity	2.0
Maximum Design Service Temperature	23 °c
Standard	AS/NZS 4766



PRODUCT CODE:

PTRNFE6200

DESCRIPTION:

6,200 GALLON / 28,000L LIQUID FERTILISER TANK