

## PRODUCT SHEET



DIAMETER	2500 MM
MAN HOLE HEIGHT	1160 MM
OVERALL HEIGHT	1410 MM

**PRODUCT CODE:  
PTRNMO1100SQ**

**1,100GAL / 5,000L MOLASSES SQUAT TANK**

### FEATURES

- Specific Gravity of 1.6 (2.0 optional)
- Fully self supporting roof (no internal poles or frames)
- Manufactured from proven Australian standard materials (tested in the field for over 25 years)
- Manufactured in computerised ovens (not open flame)
- Ribbed side walls (extra strength)
- Thicker walls at base (supports pressure)
- Poly fused & welded fittings (stops fitting split)

### FREE INCLUSIONS<sup>1</sup>

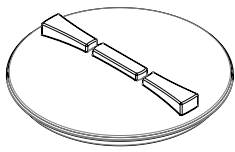
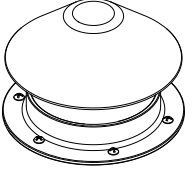
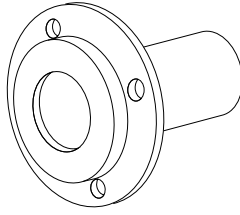
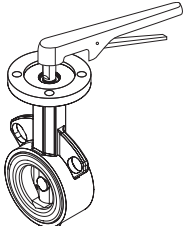
355mm Screw Cap Manhole	Centre Vent
	
Stub Flange	Butterfly Valve
	

<sup>1</sup> Standard sizing of Butterfly Valve and Stub Flange 3", 4" and 6", other sizes available on request

\*Inclusions may change without notice, check with sales prior to ordering

### COLOURS AVAILABLE

Black

NB: Colours may vary due to screen and printer calibrations.

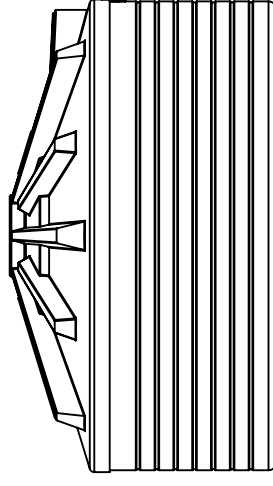
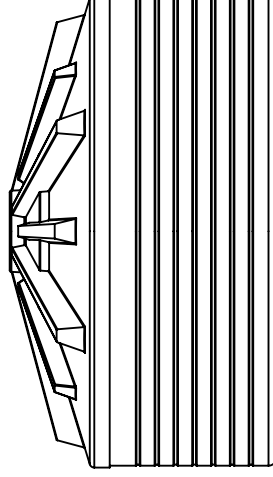
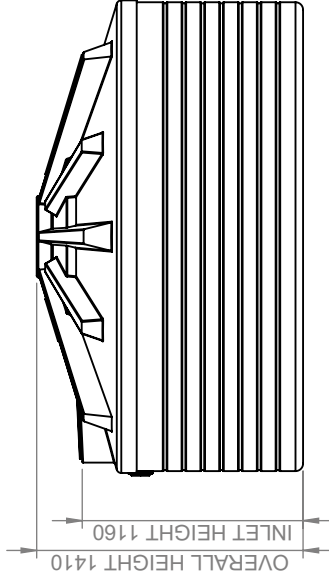
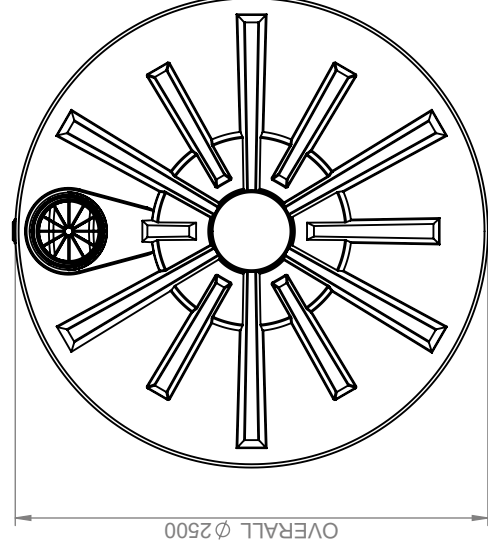

Details

Manufacturer's Name	Nu-Tank Pty Ltd
Tank Capacity	1,100 Gallon
Maximum Specific Gravity	2.0
Maximum Design Service Temperature	23 °c
Standard	AS/NZS 4766



PRODUCT CODE:

PTRNMO1100SQ

DESCRIPTION:

1,100GAL /5,000L SQ MOLASSES TANK