

PRODUCT SHEET



DIAMETER	2500 MM
MAN HOLE HEIGHT	1800 MM
OVERALL HEIGHT	2000 MM

**PRODUCT CODE:
PTRNMO1750**

1,750GAL / 8,000L MOLASSES TANK

FEATURES

- Specific Gravity of 1.6 (2.0 optional)
- Fully self supporting roof (no internal poles or frames)
- Manufactured from proven Australian standard materials (tested in the field for over 25 years)
- Manufactured in computerised ovens (not open flame)
- Ribbed side walls (extra strength)
- Thicker walls at base (supports pressure)
- Poly fused & welded fittings (stops fitting split)

FREE INCLUSIONS¹

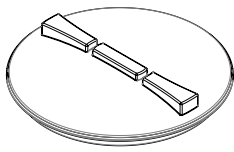
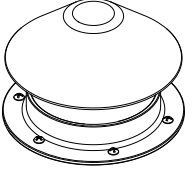
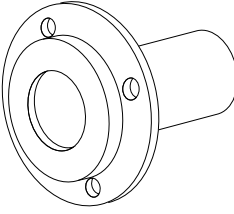
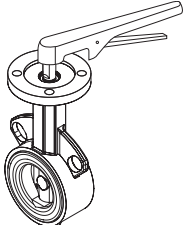
355mm Screw Cap Manhole	Centre Vent
	
Stub Flange	Butterfly Valve
	

¹ Standard sizing of Butterfly Valve and Stub Flange 3", 4" and 6", other sizes available on request

*Inclusions may change without notice, check with sales prior to ordering

COLOURS AVAILABLE

Black

NB: Colours may vary due to screen and printer calibrations.

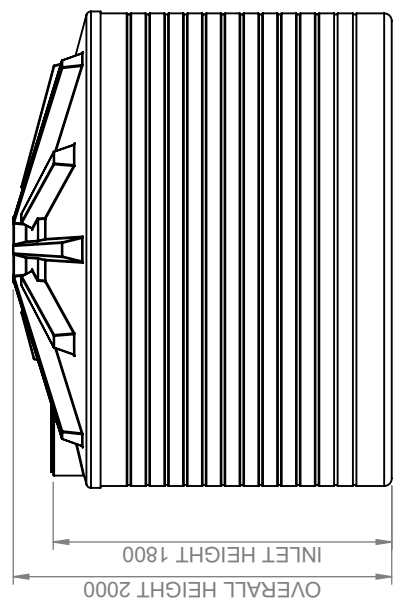
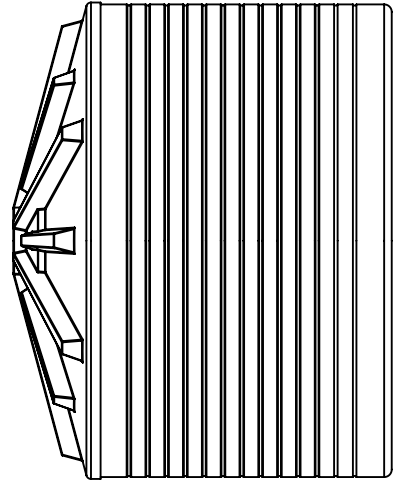
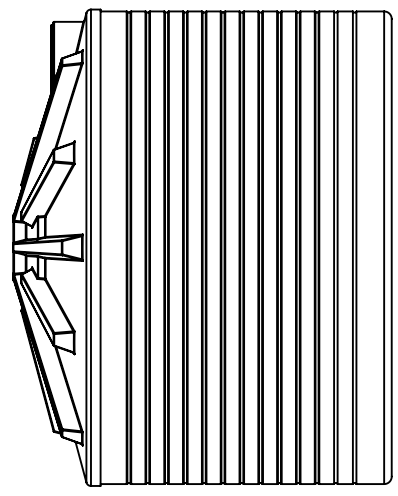
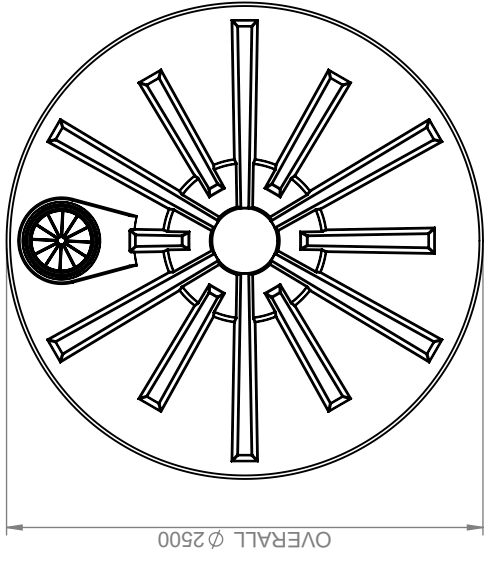

PRODUCT CODE:
PTRNMO1750

DESCRIPTION:
1,750 GALLON / 8,000 LITRE MOLASSES TANK

Details

Manufacturer's Name	Nu-Tank Ply Ltd
Tank Capacity	1,750 Gallon
Maximum Specific Gravity	2.0
Maximum Design Service Temperature	23°C
Standard	AS/NZS 4766