

PRODUCT SHEET



Tank as seen in Mist Green

DIAMETER	1800 MM
INLET HEIGHT	1000 MM
OVERALL HEIGHT	1200 MM

**PRODUCT CODE:
PTRNWA550SQ**

550GAL /2,500L SQUAT WATER TANK

FEATURES

- Fully self supporting roof (no internal poles or frames)
- Manufactured from proven UV stabilised Australian standard materials (tested in the field for over 25 years)
- Manufactured in computerised ovens (not open flame)
- Thicker walls at base (supports pressure)
- Poly fused & welded fittings (stops fitting split)

FREE INCLUSIONS¹

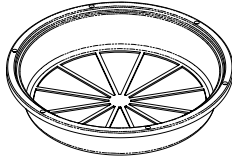
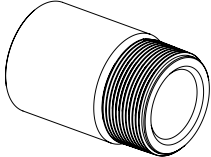
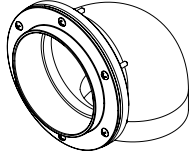
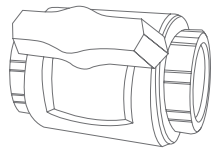
300mm Strainer & Light Guard 	Poly Fused & Welded Fitting ² 
90mm Overflow 	Ball Valve ³ 

¹ Additional fittings are available on request

² Poly Fused & Welded Fitting sizes are available in 1", 1.5" and 2"

³ Ball Valve sizes are available in 1", 1.5" and 2"

*Inclusions may change without notice, check with sales prior to ordering

COLOURS AVAILABLE

CB Surf Mist	Birch Grey (CB Dune)	CB Shale Grey	Armour Grey (CB Windspray)	CB Wallaby	CB Basalt	Slate Grey (CB Woodland Grey)
CB Monument	Black (CB Night Sky)	Mountain Blue (CB Deep Ocean)	Metal Grey (CB Ironstone)	CB Cove	Evening Haze	Merino Beige (CB Paperbark)
Gully	CB Jasper	Smooth Cream (CB Classic Cream)	Desert Haze (CB Sandbank)	Wheat	Earthtone (CB Bushland)	CB Mangrove
Mist Green (CB Pale Eucalypt)	Rivergum (CB Wilderness)	Heritage Green (CB Cottage Green)	Heritage Red (CB Manor Red)	NB: COLORBOND® and colour names are registered trademarks of BlueScope Steel Limited*. Colour names, shown in brackets, are trademarks of BlueScope Steel Limited). Colours may vary due to screen and printer calibrations.		

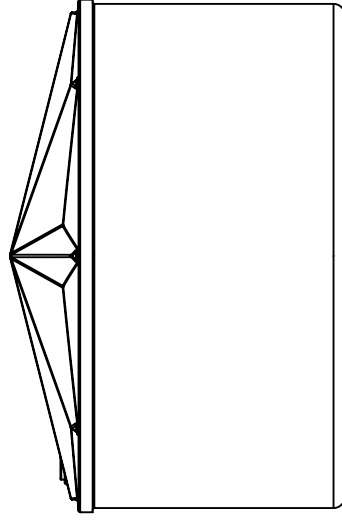
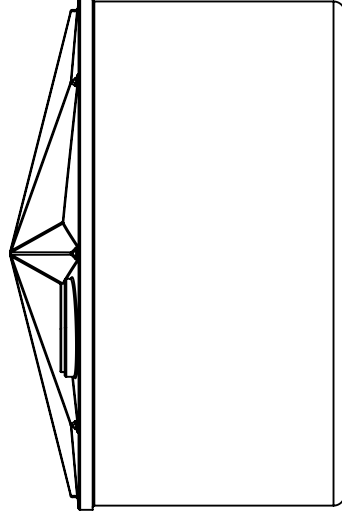
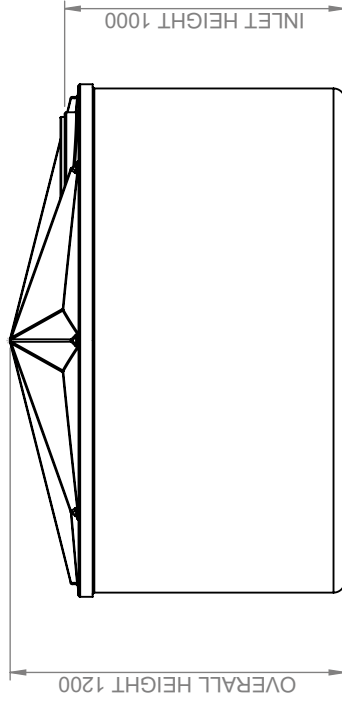
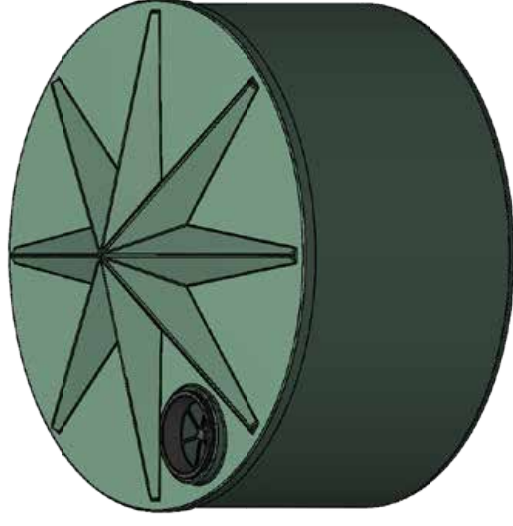
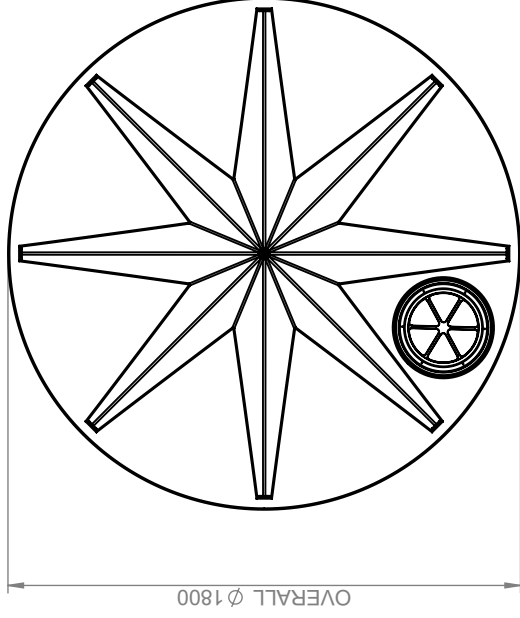

Details

Manufacturer's Name	Nu-Tank Pty Ltd
Tank Capacity	550 Gallon
Maximum Specific Gravity	1.0
Maximum Design Service Temperature	23°C
Standard	AS/NZS 4766



PRODUCT CODE:

PTRNWA550SQ

DESCRIPTION:

550 GALLON / 2,000 LITRE SQ WATER TANK