

**PRODUCT SHEET**

VIEW THIS  
PRODUCT  
ONLINE



As seen in Mountain Blue

DIAMETER	3750MM
INLET HEIGHT	2610MM
OVERALL HEIGHT	3040MM

All dimensions may vary  $\pm$  3% due to rotational moulding process.

**PRODUCT CODE:  
PTRNWA6200**

**6,200GAL / 28,000L WATER TANK**

**FEATURES**

- Fully self supporting roof (no internal poles or frames)
- Manufactured from proven UV stabilised Australian standard materials (tested in the field for over 25 years)
- Manufactured in computerised ovens (not open flame)
- Ribbed sidewall (extra strength)
- Thicker walls at base (supports pressure)
- Poly fused & welded fittings (stops fitting split)

**FREE INCLUSIONS<sup>1</sup>**

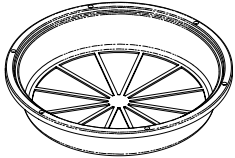
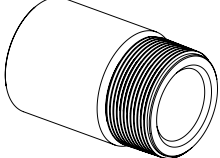
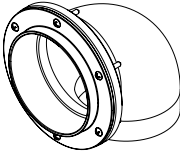
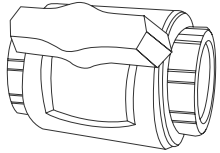
500mm Strainer & Light Guard	Poly Fused & Welded Fitting <sup>2</sup>
	
90mm Overflow	Ball Valve <sup>3</sup>
	

<sup>1</sup> Additional fittings are available on request

<sup>2</sup> Poly Fused & Welded Fitting sizes are available in 1", 1.5" and 2"

<sup>3</sup> Ball Valve sizes are available in 1", 1.5" and 2"

\*Inclusions may change without notice, check with sales prior to ordering

**COLOURS AVAILABLE**

CB Surf Mist	Birch Grey (CB Dune)	CB Shale Grey	Armour Grey (CB Windspray)	CB Wallaby	CB Basalt	Slate Grey (CB Woodland Grey)
CB Monument	Black (CB Night Sky)	Mountain Blue (CB Deep Ocean)	Metal Grey (CB Ironstone)	CB Cove	Evening Haze	Merino Beige (CB Paperbark)
Gully	CB Jasper	Smooth Cream (CB Classic Cream)	Desert Haze (CB Sandbank)	Wheat	Earthtone (CB Bushland)	CB Mangrove
Mist Green (CB Pale Eucalypt)	Rivergum (CB Wilderness)	Heritage Green (CB Cottage Green)	Heritage Red (CB Manor Red)			

NB: COLORBOND® and colour names are registered trademarks of BlueScope Steel Limited®. Colour names, shown in brackets, are trademarks of BlueScope Steel Limited). Colours may vary due to screen and printer calibrations.

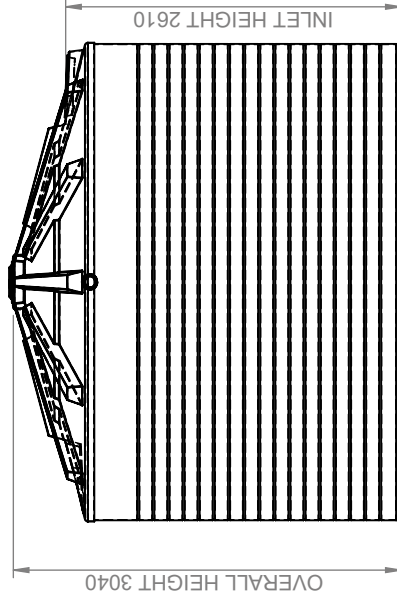
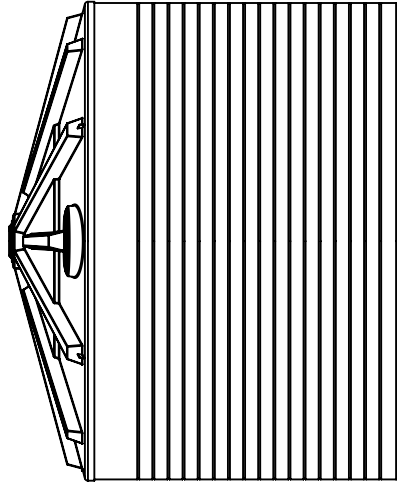
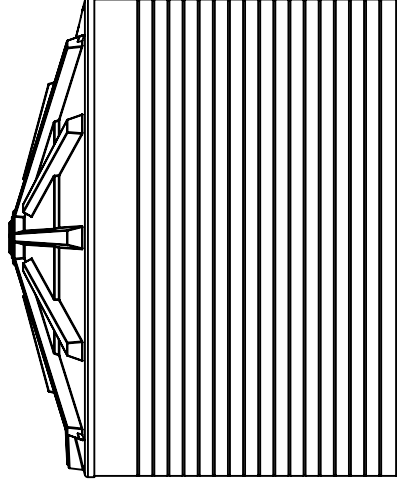
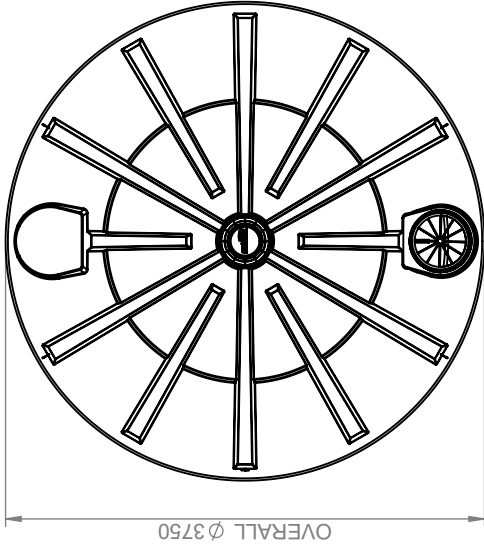
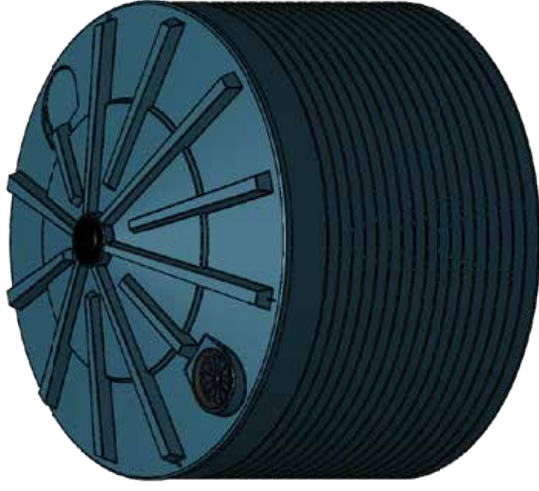

PRODUCT CODE:

PTRNWA6200

DESCRIPTION

6,200 GALLON / 28,000 LITRE WATER TANK

**Details**

Manufacturer's Name	Nu-Tank Pty Ltd
Tank Capacity	6200 Gallon
Specific Gravity	1.0
Maximum Design Service Temperature	23°C
Standard	AS/NZS 4766

All dimensions may vary ± 3% due to rotational moulding process.