

PRODUCT SHEET

VIEW THIS
PRODUCT
ONLINE



| | |
|--------|--------|
| LENGTH | 1875MM |
| WIDTH | 1420MM |
| HEIGHT | 1350MM |

All dimensions may vary \pm 3% due to rotational moulding process.

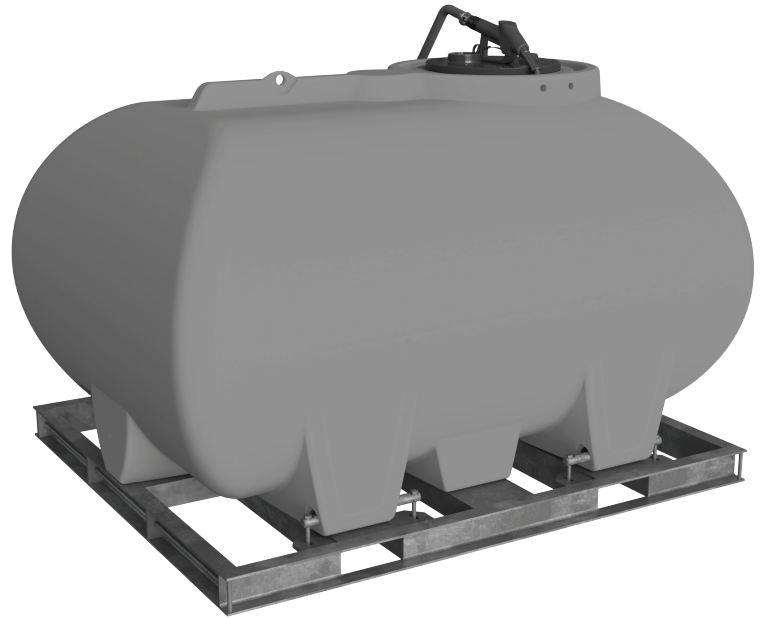



**PRODUCT CODE:
SODI2000GX25**

2,000L DIESEL SLIP-ON UNIT

FEATURES

- Lightweight alloy frame
- Fork points (for ease of handling)
- Heavy duty Diesel grade tank (material complies with AS1940-2017 and AS 2809.2-2020)
- Fully baffled for braking, stability and overall safety when in use
- Earth strap to prevent anti-static build up when filling or dispensing
- 45LPM 12V Pump
- 4m hose

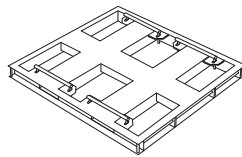
FREE INCLUSIONS

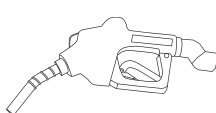
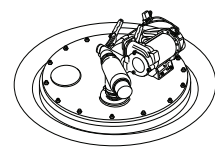
| | |
|--------------------------------------------------------------------------------------------------------------|------------------------------------------------------------------------------------------------------------------------|
| Painted Frame  | Baffle Balls  |
| Auto Shut-Off Nozzle  | Lid Mounted Pump with 4m hose  |

*Inclusions may change without notice, check with sales prior to ordering

COLOURS AVAILABLE



Grey

NB: Colours may vary due to screen and printer calibrations.

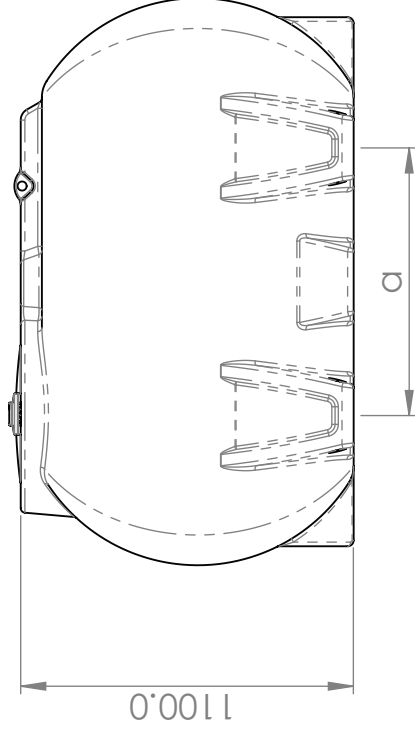
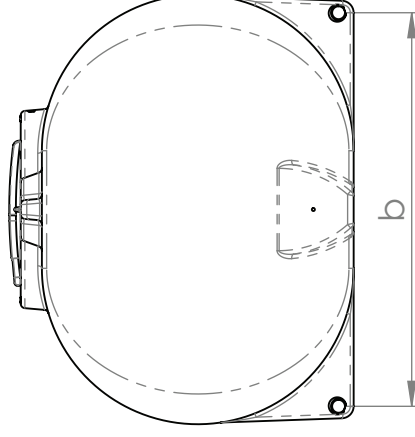
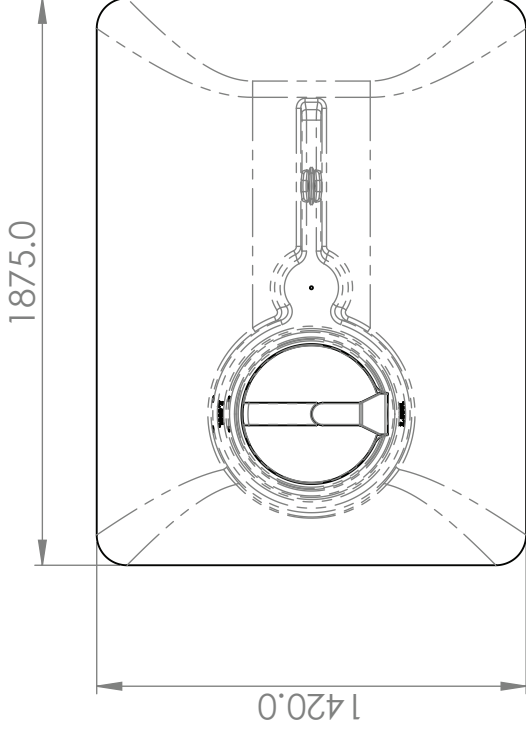

Details

| | |
|------------------------------------|-----------------|
| Manufacturer's Name | Nu-Tank Pty Ltd |
| Tank Capacity | 2000 Litre |
| Specific Gravity | 1.6 |
| Maximum Design Service Temperature | 23°C |
| Standard | AS/NZS 4766 |

| | |
|--------------------|--------|
| Leg Pitch (a) | 885MM |
| Foot Pin Pitch (c) | 1302MM |



PRODUCT CODE:

S0D2000GX25

DESCRIPTION

2,000 LITRE DIESEL SLIP-ON UNIT

All dimensions may vary ± 3% due to rotational moulding process.